

T30-XX00  
PHASE CONTROL  
THYRISTOR

SYMBOL	CHARACTERISTIC	TEST CONDITIONS	T <sub>j</sub> (°C)	VALUE			UNIT
				Min	Type	Max	
I <sub>T(AV)</sub>	Mean on-state current	180° half sine wave 50Hz Double side cooled, T <sub>hs</sub> =55°C	125			3000	A
I <sub>T(AV)</sub>	Mean on-state current	180° half sine wave 50Hz Double side cooled, T <sub>hs</sub> =80°C	125			2189	A
V <sub>DRM</sub> V <sub>RRM</sub>	Repetitive peak off-state voltage Repetitive peak reverse voltage	V <sub>DRM</sub> &V <sub>RRM</sub> tp=10ms V <sub>DSM</sub> &V <sub>RSM</sub> = V <sub>DRM</sub> &V <sub>RRM</sub> +100V respectively	125	400		1000	V
I <sub>DRM</sub> I <sub>RRM</sub>	Repetitive peak current	at V <sub>DRM</sub> at V <sub>RRM</sub>	125			160	mA
I <sub>TSM</sub>	Surge on-state current	10ms half sine wave	125			45.6	KA
I <sup>2</sup> T	I <sup>2</sup> T for fusing coordination	V <sub>R</sub> =0.6V <sub>RRM</sub>				10396	A <sup>2</sup> s*10 <sup>3</sup>
V <sub>TO</sub>	Threshold voltage		125			0.90	V
r <sub>T</sub>	On-state slop resistance					0.10	mΩ
V <sub>TM</sub>	Peak on-state voltage	I <sub>TM</sub> =5000A, F= 35KN	125			1.41	V
dv/dt	Critical rate of rise of off-state voltage	V <sub>DM</sub> =0.67V <sub>DRM</sub>	125			300	V/μs
di/dt	Critical rate of rise of on-state current	From 67%V <sub>DRM</sub> to 2000A, Gate source 1.5A t <sub>r</sub> ≤0.5μs Repetitive	125			400	A/μs
I <sub>rm</sub>	Reverse recovery current	I <sub>TM</sub> =1500A, tp=1000μs, di/dt=-20A/μs, V <sub>r</sub> =50V	125			170	A
t <sub>rr</sub>	Reverse recovery time					18	μs
Q <sub>rr</sub>	Recovery charge					2430	μC
I <sub>GT</sub>	Gate trigger current	V <sub>A</sub> =12V, I <sub>A</sub> =1A	25	40		300	mA
V <sub>GT</sub>	Gate trigger voltage			0.8		3.0	V
I <sub>H</sub>	Holding current			20		300	mA
V <sub>GD</sub>	Non-trigger gate voltage	At 67%V <sub>DRM</sub>	125			0.3	V
R <sub>th(j-h)</sub>	Thermal resistance Junction to heatsink	At 180° sine' double side cooled Clamping force 35KN				0.016	°C /W
F <sub>m</sub>	Mounting force			30		40	KN
T <sub>stg</sub>	Stored temperature			-40		140	°C
W <sub>t</sub>	Weight						g
Outline	KT60cT70						

Outline

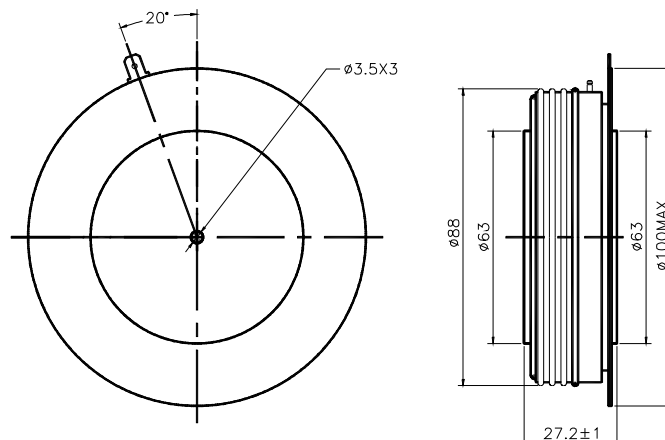

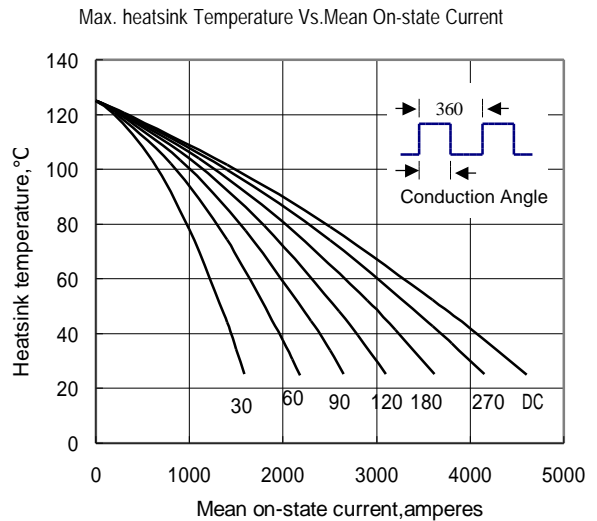
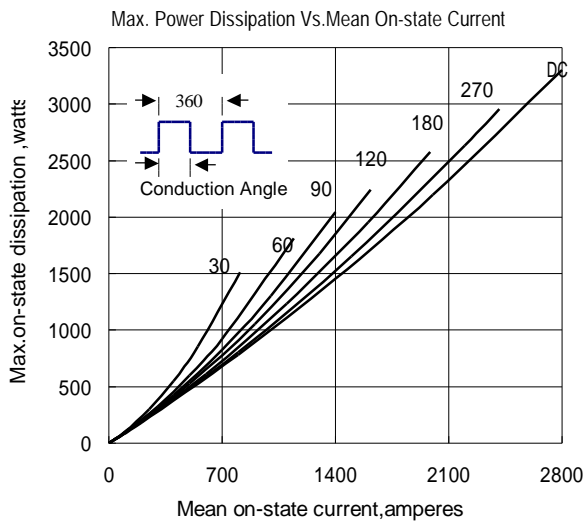
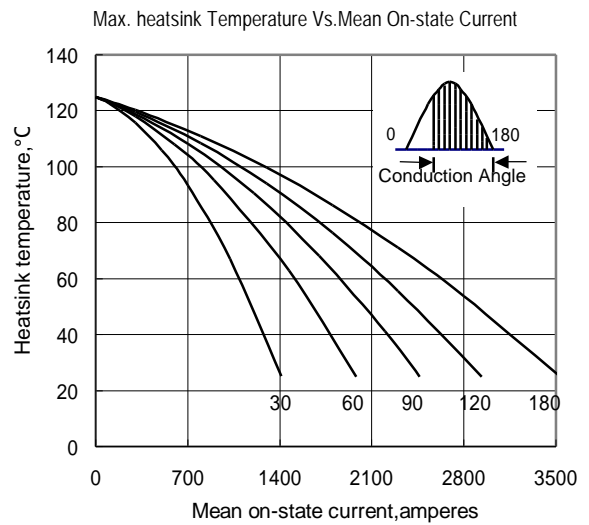
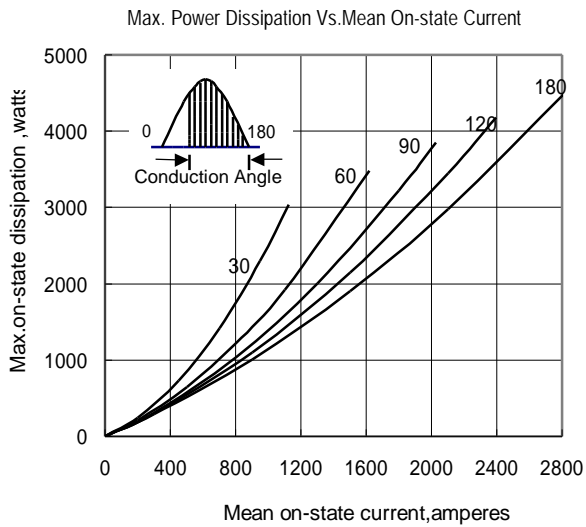
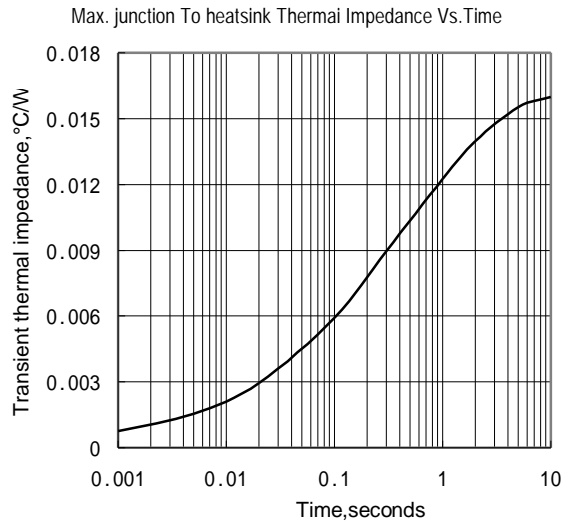
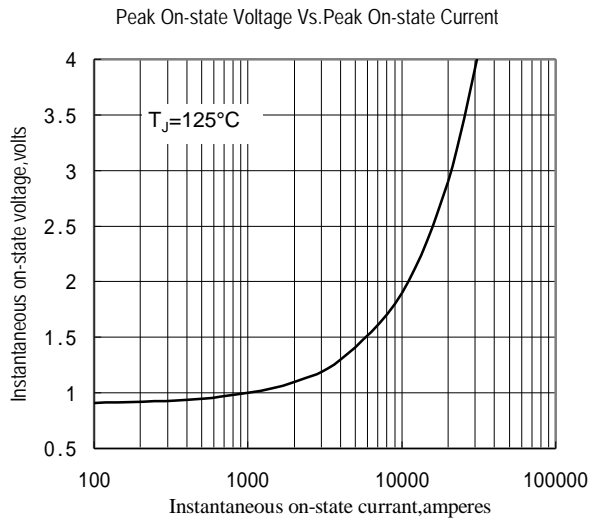

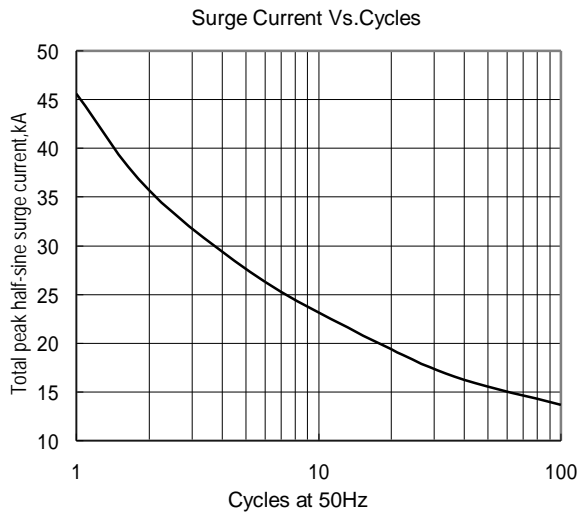

Fig.7

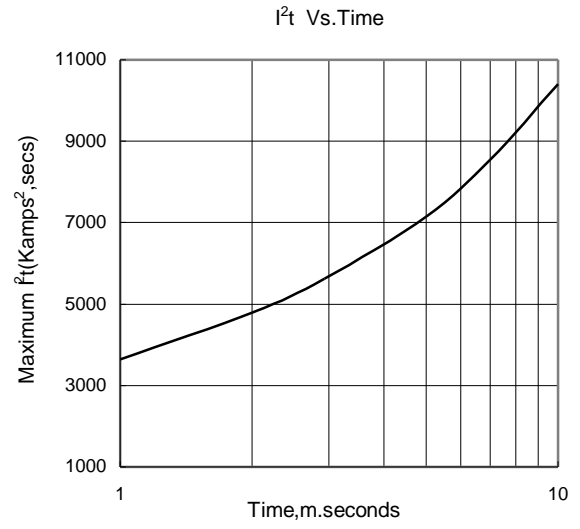

Fig.8

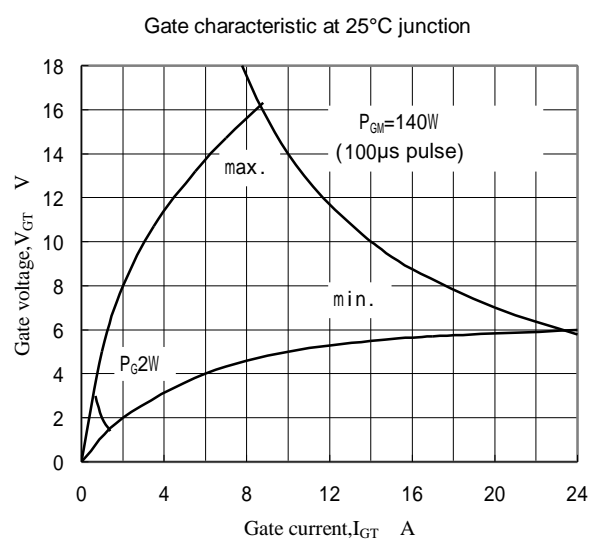

Fig.9

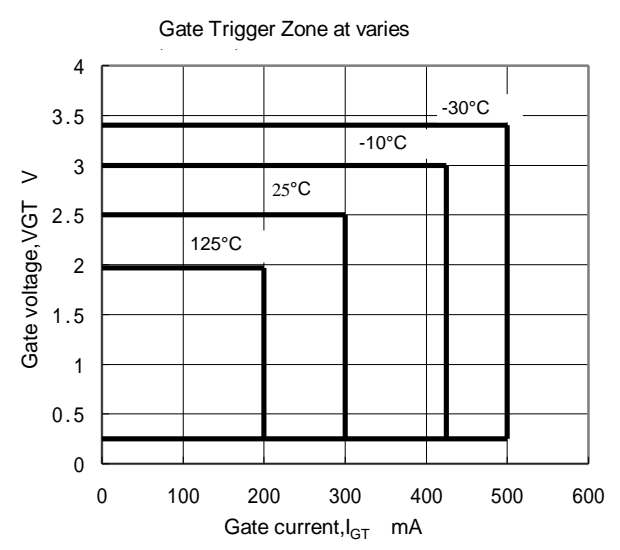

Fig.10