

SYMBOL	CHARACTERISTIC	TEST CONDITIONS	T <sub>j</sub> (°C)	VALUE			UNIT
				Min	Type	Max	
I <sub>F(AV)</sub>	Mean forward current	180° half sine wave 50Hz Double side cooled, T <sub>hs</sub> =55°C	150			2565	A
I <sub>F(AV)</sub>	Mean forward current	180° half sine wave 50Hz Double side cooled, T <sub>hs</sub> =90°C	150			1883	A
V <sub>RRM</sub>	Repetitive peak reverse voltage	V <sub>RRM</sub> tp=10ms V <sub>RSM</sub> = V <sub>RRM</sub> +100V	150	200		1000	V
I <sub>RRM</sub>	Repetitive peak current	at V <sub>RRM</sub>	150			80	mA
I <sub>FSM</sub>	Surge forward current	10ms half sine wave	150			33.3	KA
I <sup>2</sup> T	I <sup>2</sup> T for fusing coordination	V <sub>R</sub> =0.6V <sub>RRM</sub>				5559	A <sup>2</sup> s*10 <sup>3</sup>
V <sub>FO</sub>	Threshold voltage		150			0.80	V
r <sub>F</sub>	Forward slop resistance					0.14	mΩ
V <sub>FM</sub>	Peak on-state voltage	I <sub>TM</sub> =4500A, F=24KN	150			1.43	V
I <sub>rm</sub>	Reverse recovery current		150			128	A
t <sub>rr</sub>	Reverse recovery time	I <sub>TM</sub> =1000A, tp=1000μs, di/dt=-40A/μs, V <sub>R</sub> =50V				5.5	μs
Q <sub>rr</sub>	Recovery charge					352	μC
R <sub>th(j-h)</sub>	Thermal resistance Junction to heatsink	At 180° sine double side cooled Clamping force 24KN				0.022	°C /W
F <sub>m</sub>	Mounting force			19		26	KN
T <sub>stg</sub>	Stored temperature			-40		160	°C
W <sub>t</sub>	Weight				470		g
Outline	ZT50cT						

Outline

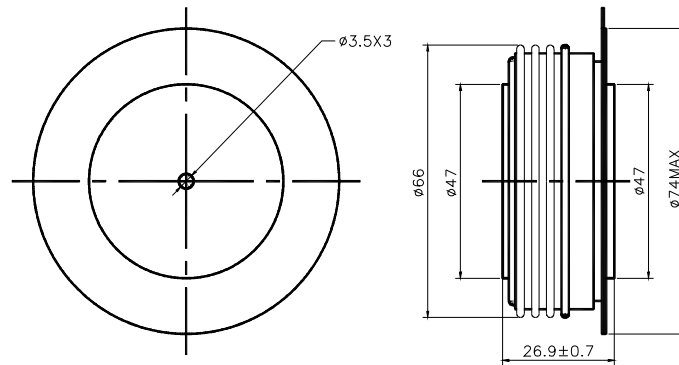

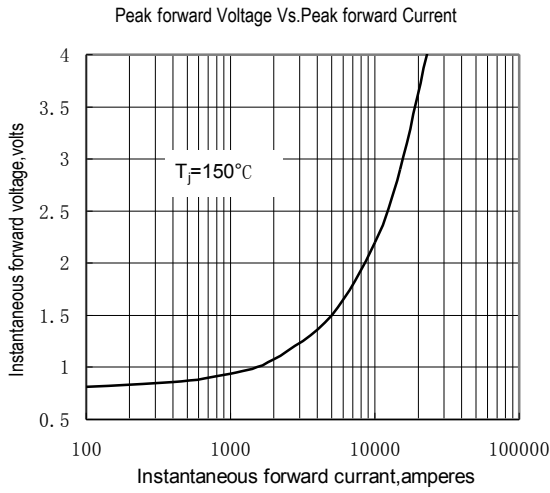

Fig.1

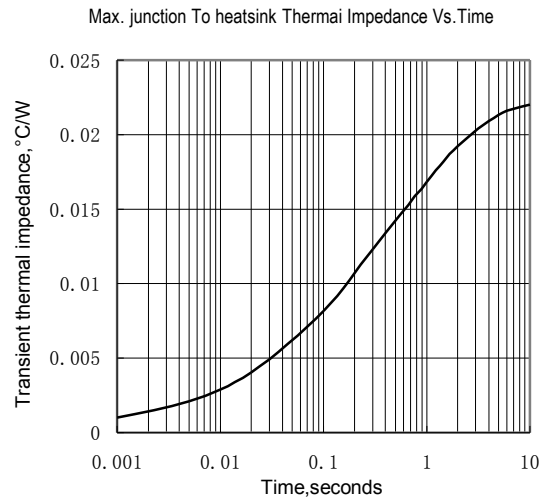

Fig.2

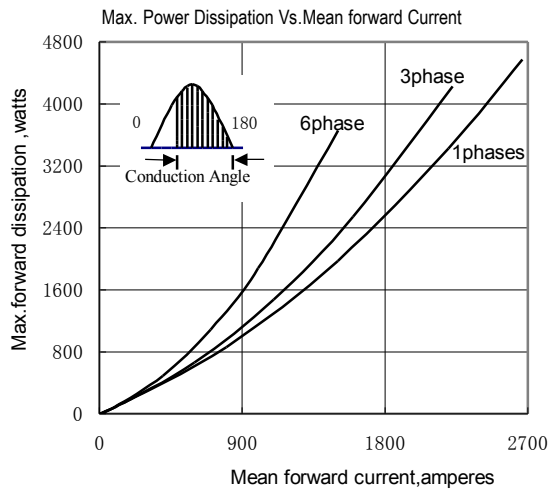

Fig.3

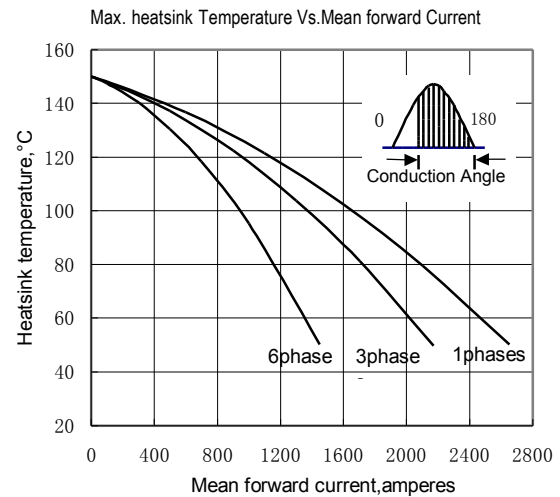

Fig.4

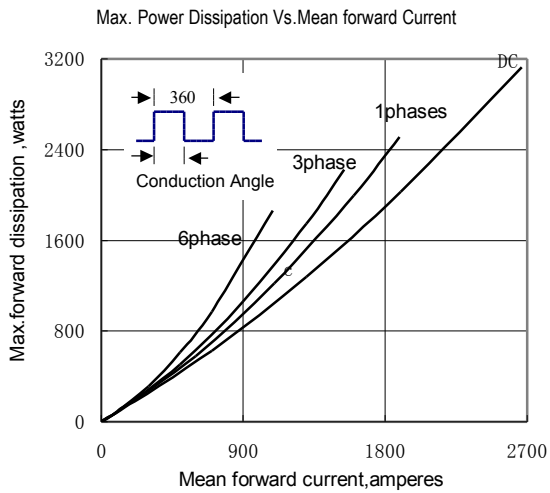

Fig.5

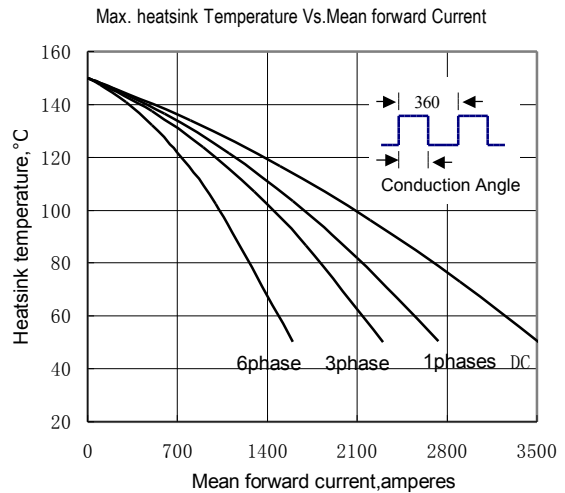

Fig.6