

3AT150 3KT150 Charged part to case non-isolated

SYMBOL	CHARACTERISTIC	TEST CONDITIONS	T _j (°C)	VALUE			UNIT
				Min	Type	Max	
I _{T(AV)}	Mean on-state current	180° half sine wave 50Hz Single side cooled, T _C =90°C	125			150	A
I _{T(RMS)}	RMS on-state current	Single side cooled, T _C =90°C	125			236	A
V _{DRM} V _{RRM}	Repetitive peak off-state voltage Repetitive peak reverse voltage	V _{DRM} &V _{RRM} tp=10ms V _{DSM} &V _{RSM} = V _{DRM} &V _{RRM} +200V respectively	125	800		1800	V
I _{DRM} I _{RRM}	Repetitive peak current	at V _{DRM} at V _{RRM}	125			12	mA
I _{TSM}	Surge on-state current	10ms half sine wave	125			5.10	KA
I ² t	I ² T for fusing coordination	V _R =60%V _{RRM}				133	A ² s*10 ³
V _{TO}	Threshold voltage		125			0.80	V
r _T	On-state slop resistance					1.74	mΩ
V _{TM}	Peak on-state voltage	I _{TM} =450A	125			1.67	V
dv/dt	Critical rate of rise of off-state voltage	V _{DM} =67%V _{DRM}	125			800	V/μs
di/dt	Critical rate of rise of on-state current	From 67%V _{DRM} to 450A, Gate source 1.5A t _r ≤0.5μs Repetitive	125			100	A/μs
I _{GT}	Gate trigger current			30		150	mA
V _{GT}	Gate trigger voltage	V _A =12V, I _A =1A	25	0.8		2.0	V
I _H	Holding current			20		100	mA
V _{GD}	Non-trigger gate voltage	At 67%V _{DRM}	125			0.2	V
R _{th(j-c)}	Thermal resistance Junction to heatsink	Single side cooled				0.160	°C /W
F _m	Thermal connection torque(M6)					0.30	N·m
	Mounting torque(M6)					0.30	N·m
T _{stg}	Stored temperature			-40		140	°C
W _t	Weight					340	g
Outline	206F4						

OUTLINE DRAWING & CIRCUIT DIAGRAM

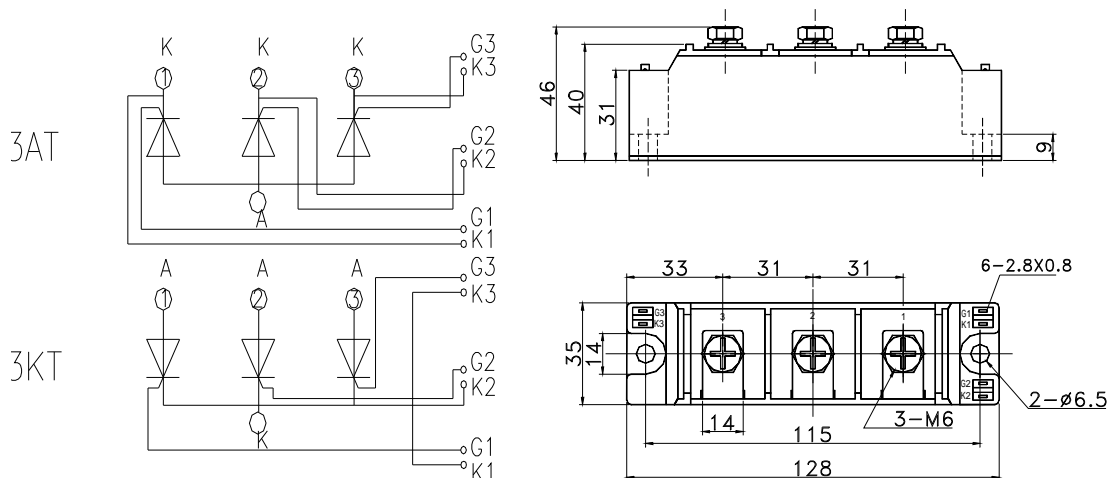

Peak forward Voltage Vs. Peak on-state Current

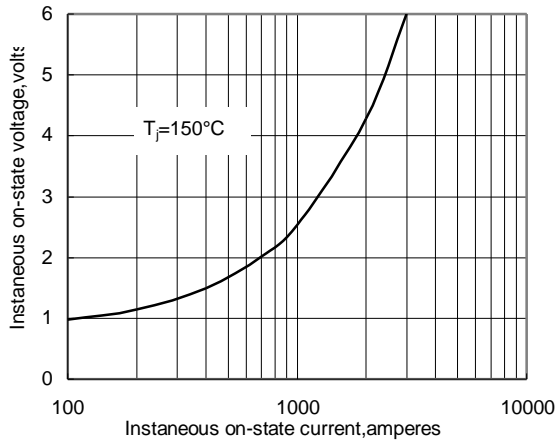

Fig.1

Max. junction To case Thermal Impedance Vs. Time

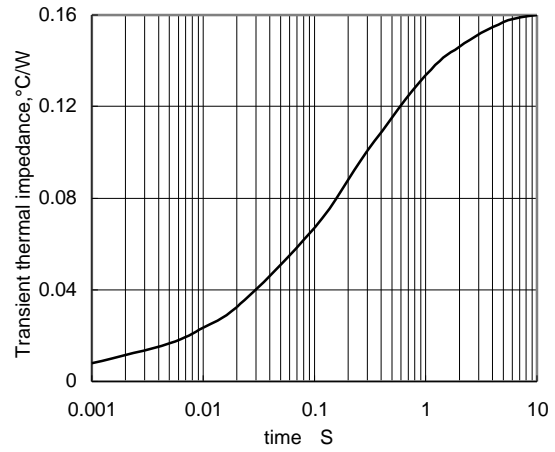

Fig.2

Max. Power Dissipation Vs. on-state Current

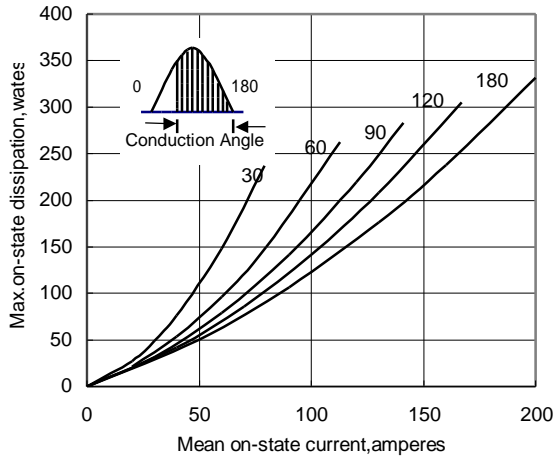

Fig.3

Max. case Temperature Vs. Mean on-state Current

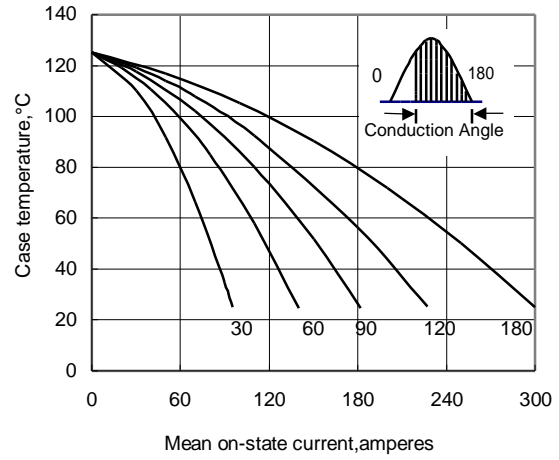

Fig.4

Max. Power Dissipation Vs. Mean on-state Current

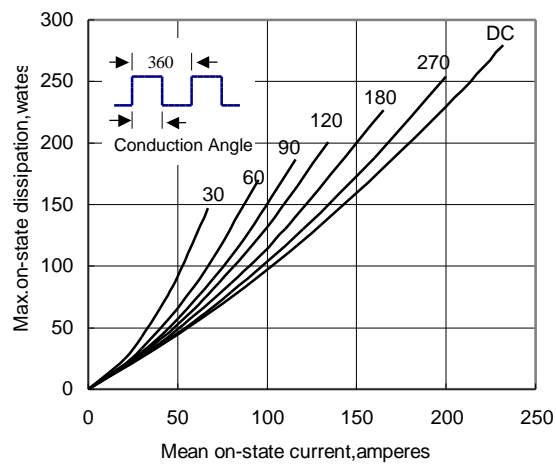

Fig.5

Max. case Temperature Vs. Mean on-state Current

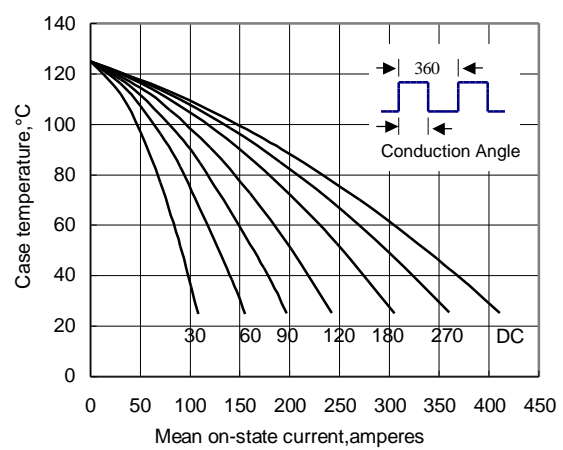

Fig.6