

3AD300 3KD300 Charged part to case non-isolated

SYMBOL	CHARACTERISTIC	TEST CONDITIONS	T _j (°C)	VALUE			UNIT
				Min	Type	Max	
I _{F(AV)}	Mean forward current	180° half sine wave 50Hz Single side cooled, T _C =100°C	150			300	A
I _{F(RMS)}	RMS forward current	Single side cooled, T _C =100°C	150			471	A
V _{RRM}	Repetitive peak reverse voltage	V _{RRM} tp=10ms V _{RSM} = V _{DRM} &V _{RRM} +200V	150	600		1800	V
I _{RRM}	Repetitive peak current	at V _{RRM}	150			25	mA
I _{FSM}	Surge forward current	10ms half sine wave	150			115	KA
I ² t	I ² T for fusing coordination	V _R =0.6V _{RRM}				674	A ² s*10 ³
V _{FO}	Threshold voltage		150			0.80	V
r _F	Forward slop resistance					0.64	mΩ
V _{FM}	Peak forward voltage	I _{FM} =900A	25			1.50	V
R _{th(j-c)}	Thermal resistance Junction to heatsink	Single side cooled				0.130	°C /W
F _m	Terminal connection torque(M5)					4.5	N·m
	Mounting torque(M6)					3.0	N·m
T _{stg}	Stored temperature			-40		125	°C
W _t	Weight					680	g
Outline	404F4						

OUTLINE DRAWING & CIRCUIT DIAGRAM

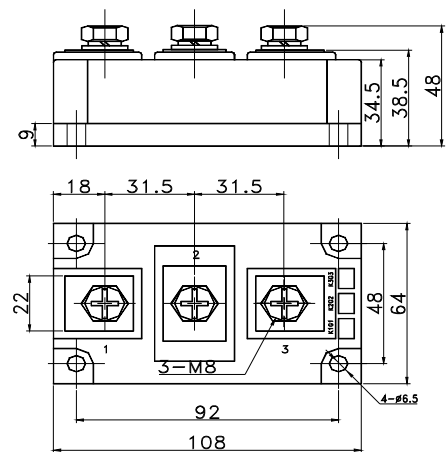
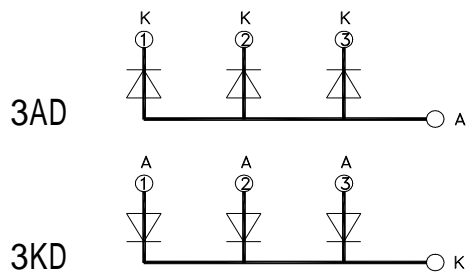

Peak forward Voltage Vs. Peak forward Current

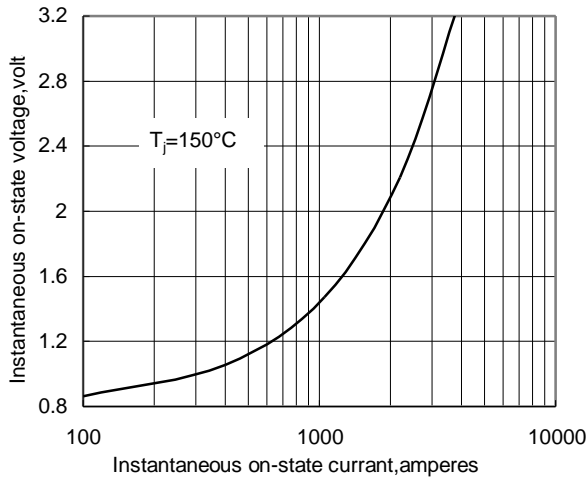

Fig.1

Max. junction To case Thermal Impedance

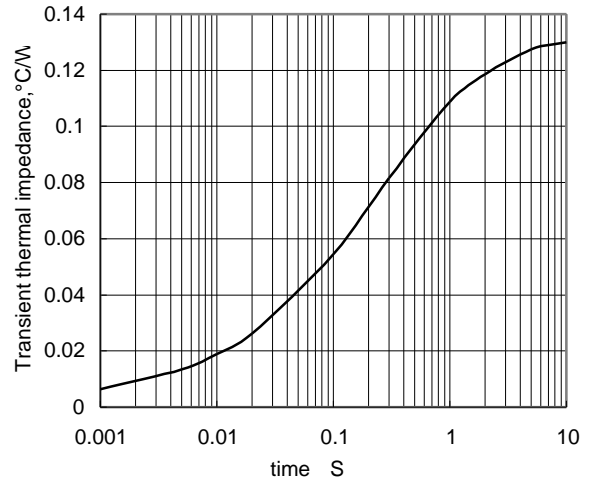

Fig.2

Max. Power Dissipation Vs. Mean forward Current

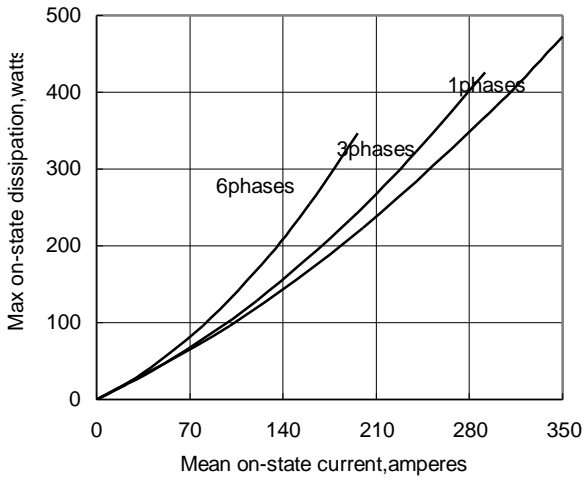

Fig.3

Max. case Temperature Vs. Mean forward Current

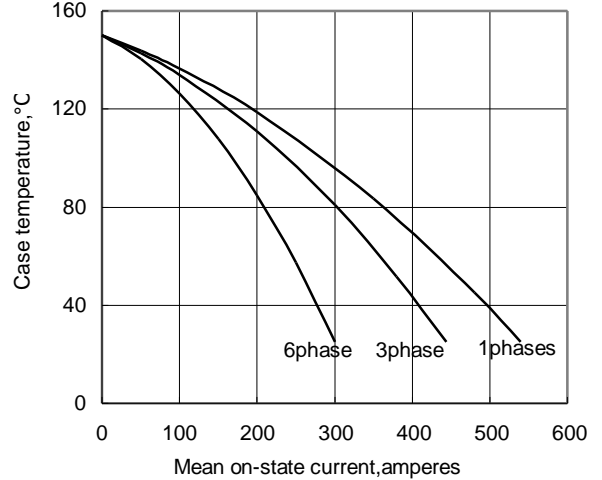

Fig.4

Max. Power Dissipation Vs. Mean forward Current

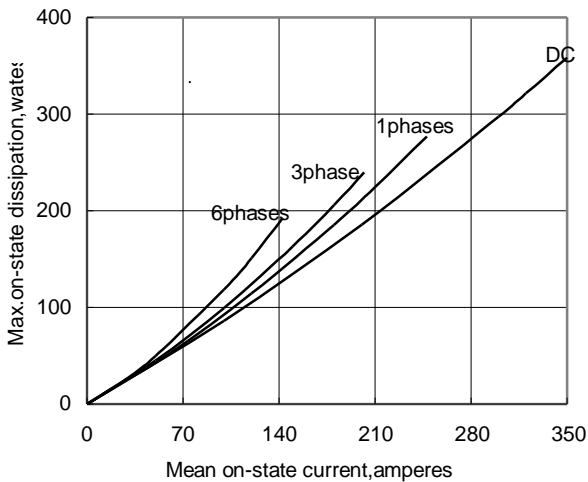

Fig.5

Max. case Temperature Vs. Mean forward Current

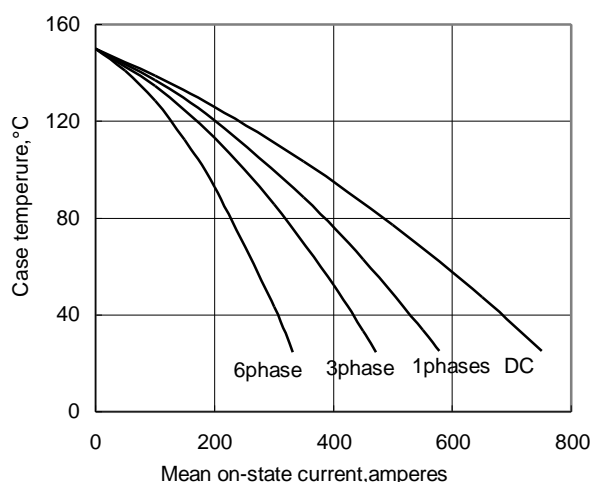

Fig.6