

3D150

SYMBOL	CHARACTERISTIC	TEST CONDITIONS	T _j (°C)	VALUE			UNIT
				Min	Type	Max	
I _o	DC output current	Three-phase full wave rectifying circuit, T _c =100°C	150			150	A
V _{RRM}	Repetitive peak reverse voltage	V _{RRM} tp=10ms V _{RSM} = V _{DRM} &V _{RRM} +200V	150	600		1800	V
I _{RRM}	Repetitive peak current	at V _{RRM}	150			10	mA
I _{FSM}	Surge forward current	10ms half sine wave	150			2.5	KA
I ² t	I ² T for fusing coordination	V _R =0.6V _{RRM}					31.8
V _{FO}	Threshold voltage		150			0.80	V
r _F	Forward slop resistance						3.8
V _{FM}	Peak forward voltage	I _{FM} =150A	25			1.37	V
R _{th(j-c)}	Thermal resistance Junction to heatsink	Single side cooled				0.150	°C /W
V _{iso}	Isolation voltage	50Hz,R.M.S,t=1min,I _{iso} :1mA(max)		2500			V
F _m	Terminal connection torque(M4)					1.5	N·m
	Mounting torque(M6)					3.0	N·m
T _{stg}	Stored temperature			-40		125	°C
W _i	Weight					480	g
Outline	410F5						

OUTLINE DRAWING & CIRCUIT DIAGRAM

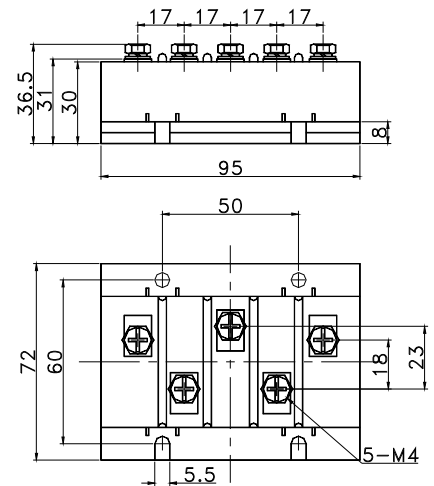

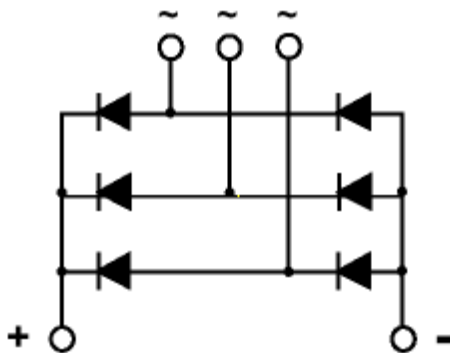
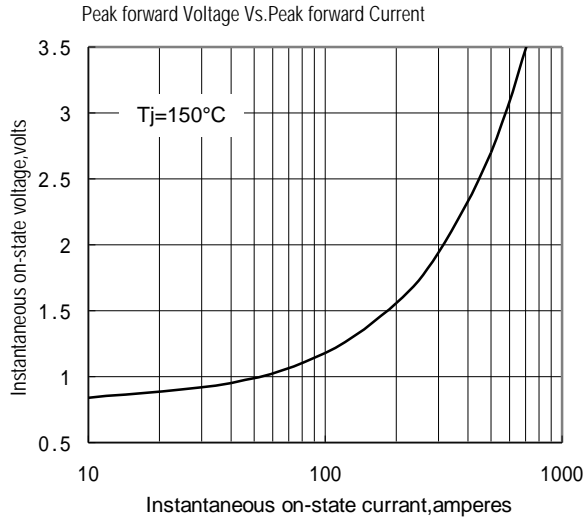

Fig.1

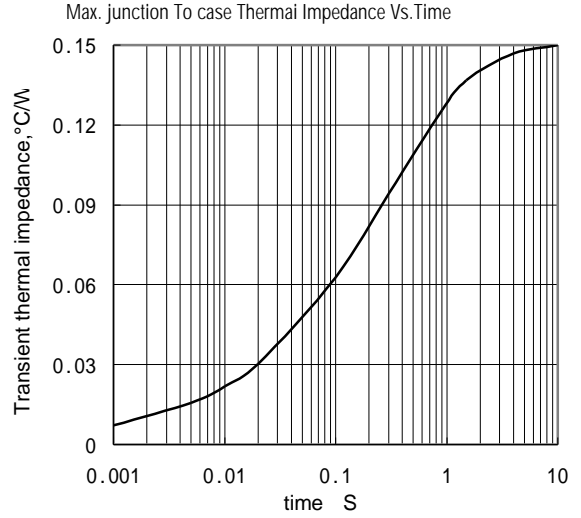

Fig.2

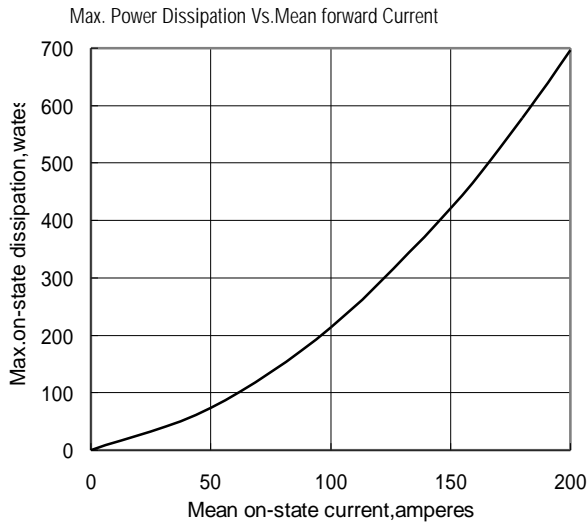

Fig.3

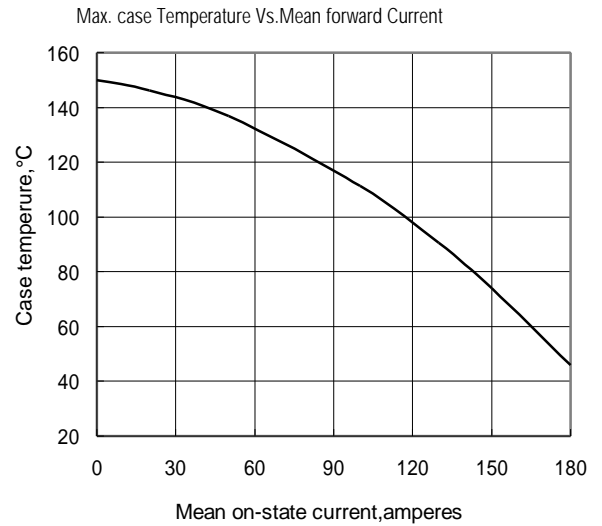

Fig.4

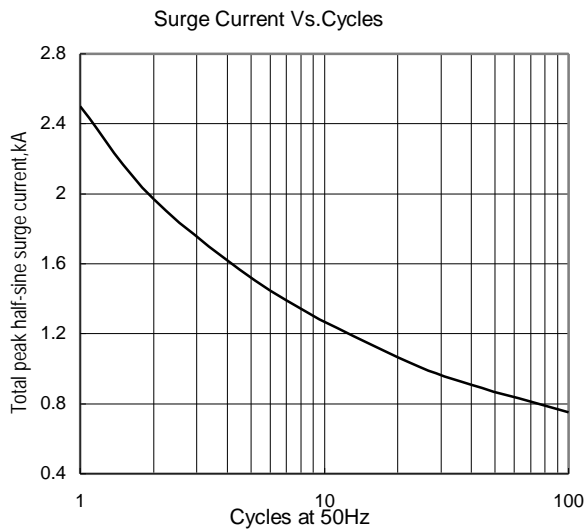

Fig.5

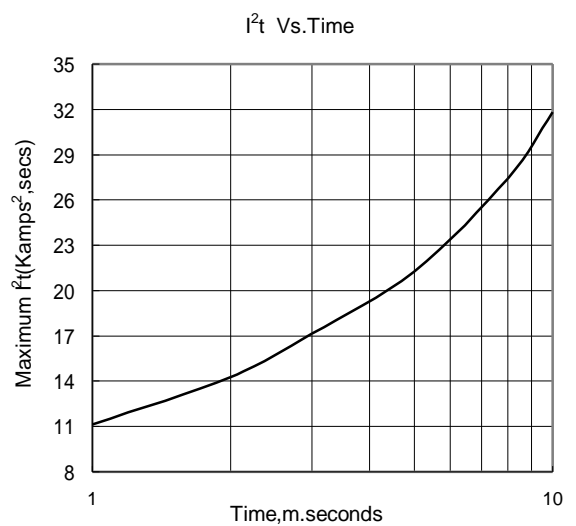

Fig.6