

**2D50**

SYMBOL	CHARACTERISTIC	TEST CONDITIONS	T <sub>j</sub> (°C)	VALUE			UNIT
				Min	Type	Max	
I <sub>O</sub>	DC output current	Single-phase full wave rectifying circuit, T <sub>C</sub> =100°C	150			50	A
V <sub>RRM</sub>	Repetitive peak reverse voltage	V <sub>RRM</sub> tp=10ms V <sub>RSM</sub> = V <sub>DRM</sub> &V <sub>RRM</sub> +200V	150	600		1800	V
I <sub>RRM</sub>	Repetitive peak current	at V <sub>RRM</sub>	150			8	mA
I <sub>FSM</sub>	Surge forward current	10ms half sine wave	150			0.75	KA
I <sup>2</sup> t	I <sup>2</sup> T for fusing coordination	V <sub>R</sub> =0.6V <sub>RRM</sub>					2.8
V <sub>FO</sub>	Threshold voltage		150			0.80	V
r <sub>F</sub>	Forward slop resistance						9.0
V <sub>FM</sub>	Peak forward voltage	I <sub>FM</sub> =75A	25			1.547	V
R <sub>th(j-c)</sub>	Thermal resistance Junction to heatsink	Single side cooled				0.55	°C /W
V <sub>iso</sub>	Isolation voltage	50Hz,R.M.S,t=1min,I <sub>iso</sub> :1mA(max)		2500			V
F <sub>m</sub>	Terminal connection torque(M4)					1.5	N·m
	Mounting torque(M6)					3.0	N·m
T <sub>stg</sub>	Stored temperature			-40		125	°C
W <sub>t</sub>	Weight					200	g
Outline	207F4						

**OUTLINE DRAWING & CIRCUIT DIAGRAM**

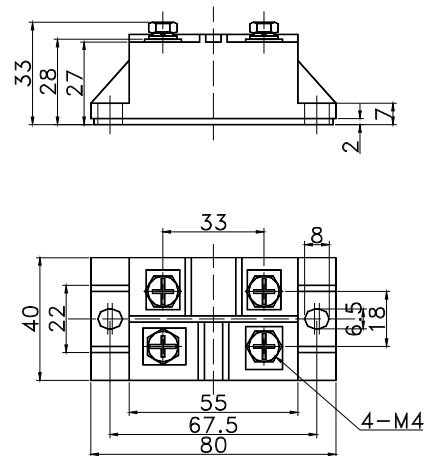

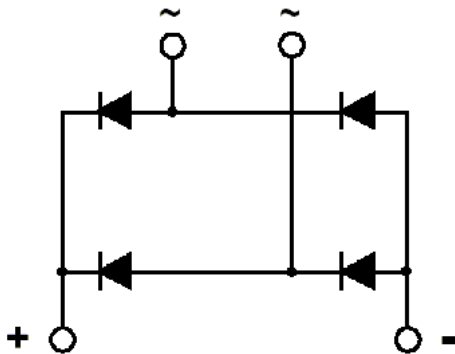
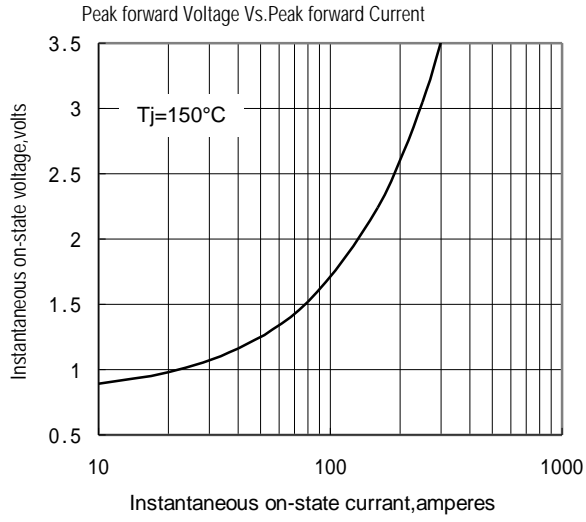

Fig.1

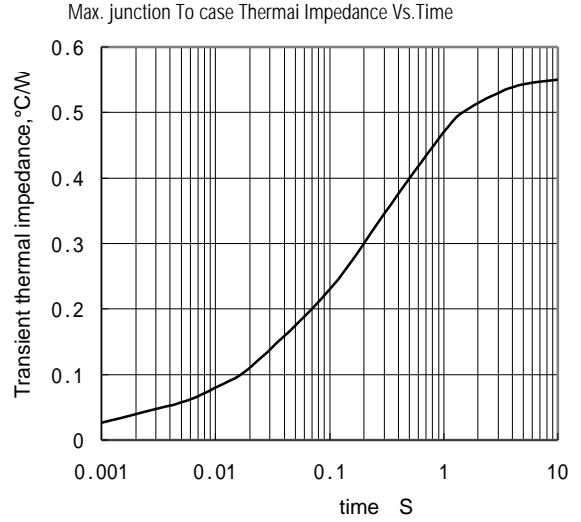

Fig.2

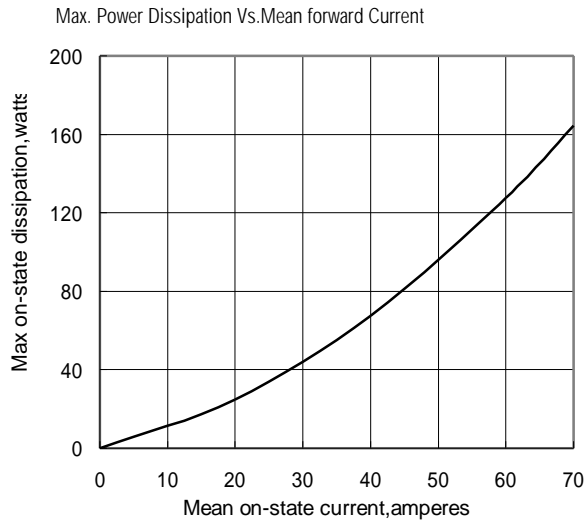

Fig.3

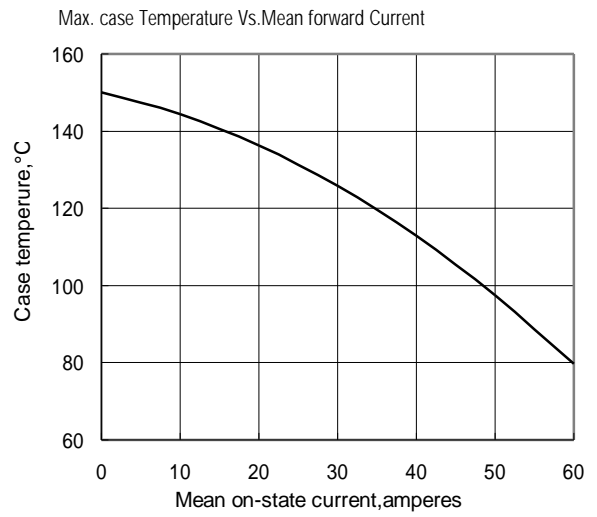

Fig.4

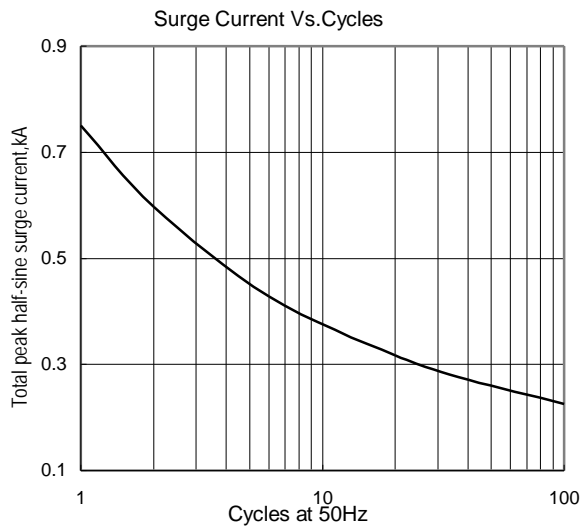

Fig.5

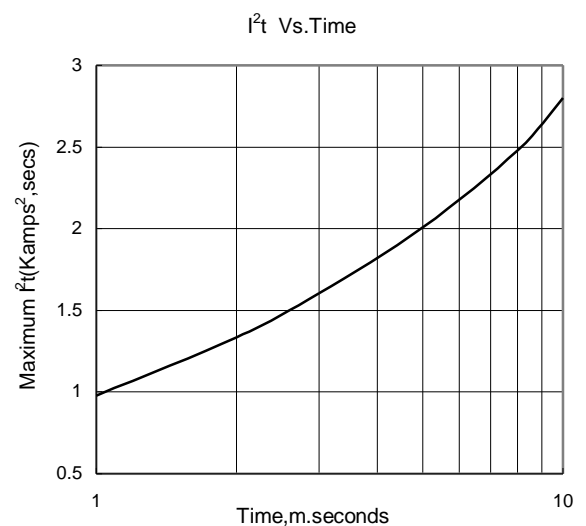

Fig.6